



Bachelor of Science in
Computer Science

Advising Brochure
2017 – 2018

Department of
Computer Science & Engineering
College of Arts & Sciences

256 Avery Hall

cseadvising@unl.edu
<http://cse.unl.edu/advising>

The B.S. Degree in Computer Science is accredited by
the Computing Accreditation Commission of ABET.
<http://www.abet.org>

rev: September 29, 2017

Computer Science Major Requirements

72-73 Hours of CSCE, MATH, and Natural Science Courses

Computer Science & Engineering Courses: (45-46 hours)

- max 6 hrs P/NP for CSCE with permission (3 for MATH if minor)
- min 13 hrs of CSCE/RAIK/MATH @ 400 level
- min grade of C for CSCE/RAIK/minors
- for our graduate program: + prereq; ! deficiency

	Course	Title	Raikes		Hrs
			RAIK	Hrs	
	CSCE 10	CSE Freshman Seminar		0	0
+	CSCE 155	Introduction to Comp Sci I	183H	4	3
+	CSCE 156	Introduction to Comp sci II	184H	4	4
+	CSCE 231	Computer System Engr		4	4
+	CSCE 235	Introduction to Discrete Struct	(283H)	0	3
	CSCE 251	Unix Programming		1	1
+	CSCE 310	Data Structures & Algos	283H	3	3
!	CSCE 322	Programming Lang Concepts		3	3
	CSCE 361	Intro to Software Engineering	383H	3	3
	CSCE 486	CS Professional Development	401H	3	3
	CSCE 487	CS Senior Design Project	402H	3	3
!	CSCE 351/451	OS Kernels or OS Principles		3	3
	CSCE 423/428	Des & An Algos or Automata		3	3
	CSCE 3/4 _____	<i>Technical Elective - lecture</i>	370H	3	3
	CSCE 3/4 _____	<i>Technical Elective - lecture</i>	371H	3	3
	CSCE 3/4 _____	<i>Technical Elective</i>	403H	3	3
		(Raikes only <i>Technical Elective</i>)	404H	<u>3</u>	<u>3</u>
				46	45
Mathematics Courses:					
+	MATH 106	Calculus I		5	5
+	MATH 107	Calculus II		4	4
!	MATH 314	Linear Alg (Matrix Theory)		3	3
!	STAT 380	Statistics & Applications	270,370	<u>3</u>	<u>3</u>
	Add MATH 208	Calculus III (4 hr) for Math Minor!		15	15

Natural Science Courses:

12

Most are 4 hours so need at least 3 courses. Must include at least one lab (**bold face**). Choose from the following (or more advanced):

- CHEM **109** & **110** or **113** & 114 and **221**, 261/**262**, 263/**264**
- PHYS **141** or 211/**221**, **142** or 212/**222**, 213/**223**
- ASTR 204/**224**
- LIFE 120/**120L**, 121/**121L** BIOS 206/**205**, **207**
- GEOL **101**, **103**, **210**, **211**, **310**, **340**
- METR **100**, 205, **223**, 311, 312, **323**, **341**
- GEOG **155**, 181
- ANTH 242/**242L**

Computer Science Major Requirements

I. Major Area of Study: 72 hours		
Computer Science / Raikes	45	
(Earn an optional Focus with all 3 technical electives in one area)		
Mathematics	15	
Natural Science	12	
II. Minor Area of Study: Suggest MATH 208 to complete the Mathematics minor!		4-18
III. ACE Student Learning Outcomes: 6-18 hours		
Max of 9 hrs in any one depart for ACE 4-10		Raikes
1. Written Communication	–	3
2. Oral Communication	–	3
3. Math & Computation	–	–
4. Natural Sciences	–	–
5. Humanities/History	3	3
6. Social Sciences	–	3
7. Fine Arts	3	3
8. Ethics	–	–
9. Human Diversity	3	3
10. Integrated Knowledge	–	–
See http://ace.unl.edu/ for details and listings.		
IV. College Distribution Requirements: 9-25 hours		
(In addition to and distinct from ACE)		
A. Written Communication (another ACE 1)		3
B. Math and Science		–
C. Humanities/History (CLAS,ENGL,HIST,PHIL,RELG)		3
D. Social Sciences (ANTH,COMM,GEOG,POLS,PSYC,SOCI)		3
E. Foreign Language 101 ₅ , 102 ₅ , 201 ₃ , 202 ₃ (Spanish option: 110 ₆ , 210 ₆) (need 202 or 210, 4 years HS, or ESL)		0-16
F. Additional CD not from CSCE		–
V. Electives: 0-17 hours		0-17
Total hours for the degree:		120

CSCE Technical Electives

Informatics Focus:

411	Data Modeling for Sys Dev	?
413	Database Systems	f
464	Internet Systems & Programming	s
470	Computer Graphics	fe
471	Bioinformatics	?
472	Digital Image Processing	f
473	Computer Vision	so
474	Data Mining	se

Artificial Intelligence Focus:

421	Foundations of Constraint Sat Theory	se
475	Multiagent Systems	fo
476	Artificial Intelligence	fo
478	Machine Learning	fe
479	Neural Networks	?

Networking & High-End Computing Focus:

351	Operating System Kernels	f+so
430	Computer Architecture (grad school def.)	s
434	VLSI Design	?
435	Cluster & Grid Computing	fo
436	Advanced Embedded Systems	fo
438	Sensor Networks	se
439	Robotics	fo,17
451	Operating System Principles	s,fo
455	Distributed Operating Systems	so
456	Parallel Algorithms & Programming	fe
457	Systems Administration	fo
462	Communication Networks	s,fe
463	Data & Network Security	se,18
465	Wireless Communication Networks	fe

Foundations Focus:

421	Foundations of Constraint Sat Theory	se
423	Design & Analysis of Algorithms	s+fo
428	Automata, Computation & Formal Languages	f+so
440	Numerical Analysis	fsu+se
477	Cryptography & Computer Security	f

(Software Engineering related):

378	Human Computer Interaction	s
425	Compiler Construction	s,18
461	SOFT Adv Topics in Software Engineering	?
464	Internet Systems & Programming	s
466	SOFT Software Design and Arch	f18+3n
467	SOFT Testing, Verif and Anal	f17+3n
468	SOFT Req Elic, Modl and Anal	s18+3n
493	ILab Project (or 301/2,401/2 DS)	f/s

(Additional Choices):

399H	Honors Thesis	fssu
491 & 498	Internship & Computer Problems	fssu

(Allow 3 hrs 491 as tech elect, another 3 as open elect)

Key - f: fall s: spring su: summer e: even year o: odd year

Recent CSCE 496 Special Topics Electives

Title	Focus Area
Algorithms - Large Scale Data (so)	Informatics
AI and Heuristics in Software Engr (fo)	Software Engr
Computational Methods in Bioinfo (fe)	Informatics
Data Visualization (fe)	Informatics
Exploring Virtual Reality (s)	Informatics
Genetically Engineered Sys (fe)	Networking & High End
Human-Robot Interaction (f)	Software Engr
Molecular & Nanoscale Communication (se)	Networking & High End
Multiway Data Analysis (?)	Informatics
Perf Optimztn Comp Systm&Netwk (fo)	Networking & High End
Real-Time Systems (s)	Networking & High End
Queuing Models (fo, 17)	Foundations
Self-Managing Comp Sys (fe)	Networking & High End
Software Engineering Robotics (?)	Software Engr

Math Double Majors

Math accepts one of CSCE 423 and 428 to double-dip as a major elective. Computer Science accepts one from the following to double-dip as a technical elective. (Crosslisted courses always double-dip.)

MATH 428	Principles of Operations Research	s
MATH 432	Linear Optimization	?
MATH 433	Nonlinear Optimization	?
MATH 439	Math Models in Biology	?
MATH 450	Combinatorics	fo
MATH 452	Graph Theory	fe
MATH/CSCE 440	Numerical Analysis	fsu
MATH/CSCE 441	Approximation of Functions	?
MATH/CSCE 447	Numerical Analysis II	?

Recent Changes in the Program

ACE has been in effect since 2009. Beginning in 2012 the number of hours for the degree dropped from 125 to 120. Also, the College Distribution (CD) Requirement dropped the second course in History/Humanities.

Beginning in 2013, a restriction was placed on the choices for technical electives: At least 6 of the hours now need to be in lecture-based courses. This limits the number of internship, independent study, and Design Studio courses that can apply to just 3 hours.

In 2014 a zero credit hour CSCE 10 Orientation course was added to the requirements.

Example Eight Semester Schedule - 120 hrs

Fall 1				Spring 1			
CSCE	10	CS Sem	0	CSCE	156	CS II	4
CSCE	155	CS I	3	CSCE	235	Discrete	3
MATH	106	Calc I	5	CSCE	251	Unix	1
		ACE 1	3	MATH	107	Calc II	4
Lang	201	Language	3	Lang	202	Language	3
			<u>14</u>				<u>15</u>
Fall 2				Spring 2			
CSCE	310	Algos	3	CSCE	231	Syst Org	4
Elect		MATH 208?	4	CSCE	361	Soft Engr	3
NatSci		(with lab)	4	MATH	314	Lin Alg	3
		ACE 2	3	NatSci		(with lab)	4
		CDR A	3				<u>14</u>
			<u>17</u>				
Fall 3				Spring 3			
CSCE	322	Lang Conc	3	CSCE	3/4XX	elective	3
STAT	380	Stats	3	CSCE	3/4XX	elective	3
NatSci			4			CDR C	3
		ACE 5	3			CDR D	3
		ACE 6	3			ACE 7	3
			<u>16</u>				<u>15</u>
Fall 4				Spring 4			
CSCE	351	or 428	3	CSCE	423	or 451	3
CSCE	3/4XX	elective	3	CSCE	487	CS Sen Des	3
CSCE	486	CS Prof	3			ACE 9	3
Elect			3	Elect			3
Elect			3	Elect			2
			<u>15</u>				<u>14</u>

Departmental Advising:

<http://cse.unl.edu/undergraduate-advising-center>

Charles Riedesel (Department Advisor) 259 Avery, 472-3486, chuckr@unl.edu
(calendar at <http://cse.unl.edu/~riedesel> follow link to appointments)

Ann Koopmann (Department Advisor) 269 Avery, 472-3678

akoopmann1@unl.edu

use *MyPlan* to schedule appointments

General College Advising:

Arts & Sciences Advising Center, 107 Oldfather Hall 472-4190,

<http://cas.unl.edu/advisingcenter.html>

Transfer Students - Equivalencies:

<http://admissions.unl.edu/nebraska/equivalency.aspx>

TECHNICAL ELECTIVES

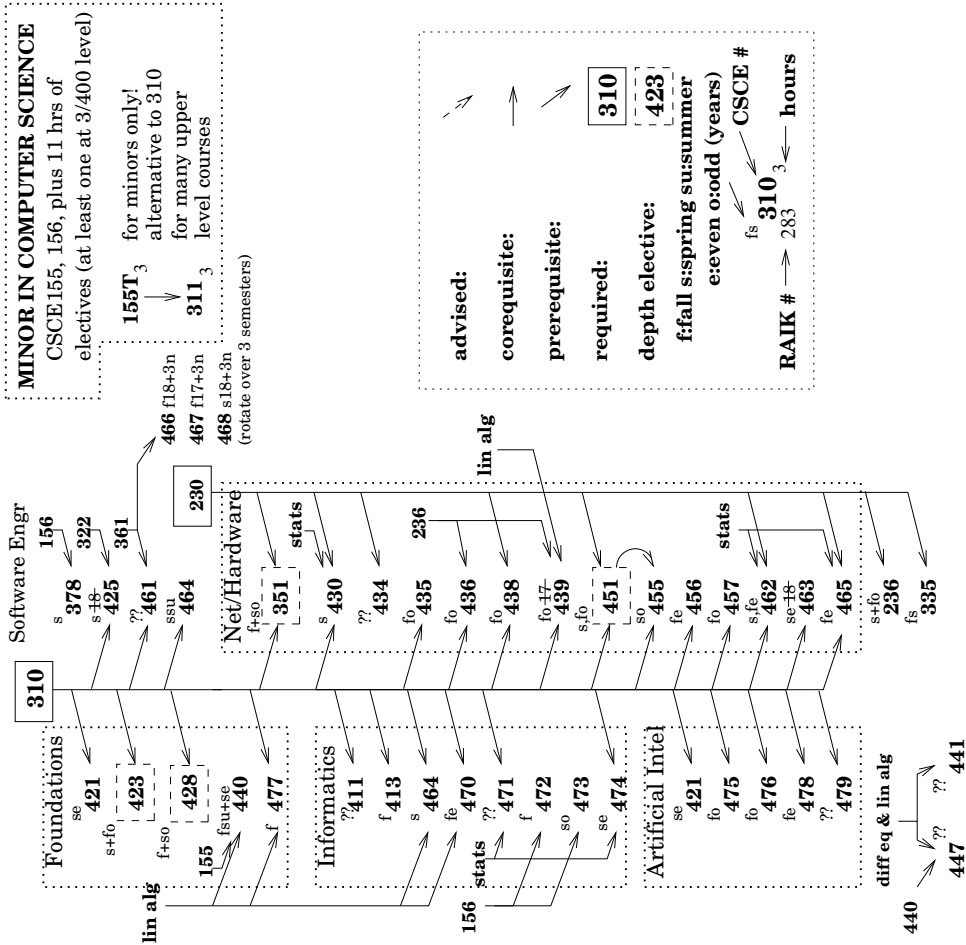

MINOR IN COMPUTER SCIENCE
 CSCE155, 156, plus 11 hrs of electives (at least one at 3/400 level)

155T₃ for minors only!
 alternative to 310
 for many upper
 level courses
 311₃

- advised: →
- corequisite: →
- prerequisite: →
- required: → **310**
- depth elective: → **423**
- f:fall s:spring sus:summer
 e:even o:odd (years)
 fs 310₃ ← hours
- RAIK # → 283

COMPUTER SCIENCE PROGRAM Computer Science & Engineering and Supporting Courses

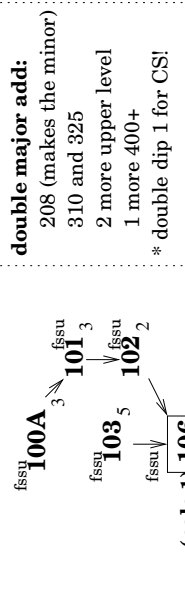
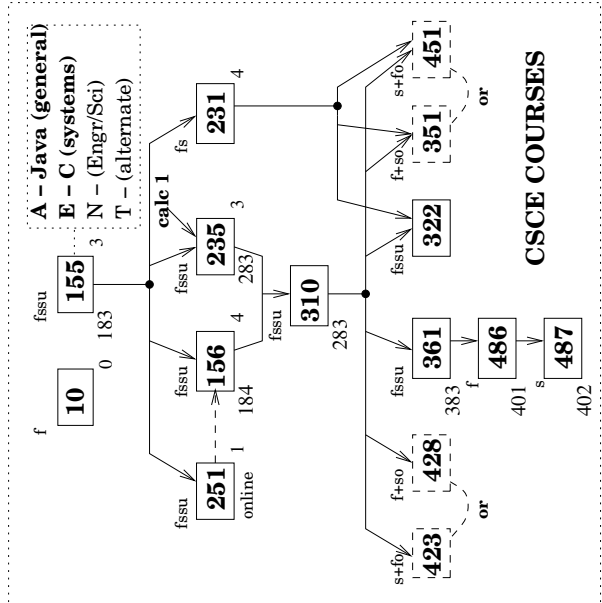

double major add:

- 208 (makes the minor)
- 310 and 325
- 2 more upper level
- 1 more 400+
- * double dip 1 for CS!