



Bachelor of Science in
Computer Engineering

Advising Brochure
2017 – 2018

Department of
Computer Science & Engineering
College of Engineering
256 Avery Hall

cseadvising@unl.edu
<http://cse.unl.edu/advising>

The B.S. Degree in Computer Engineering is accredited
by the Engineering Accreditation Commission of ABET.
<http://www.abet.org>

rev: June 7, 2017

Computer Engineering Program – 126 hours

Course	Title	RAIK	Hrs
Computer Science & Engineering Courses:			
CSCE 10, ENGR 20	Frosh & Soph Seminars		0
CSCE 155, 156	Intro to Comp Sci I,II	183,184	3,4
CSCE 230	Computer Organization		4
CSCE 235	Introduction to Discrete Struct	(283)	3
CSCE 236/ECEN 220	Intro to Embedded Systems		3
CSCE 251	Unix Programming		1
CSCE 310	Data Structures & Algos	283	3
CSCE 335/ECEN 370	Digital Logic Design		3
CSCE 351	Operating System Kernels		3
CSCE 361	Intro to Software Engineering	383	3
CSCE 440	Numerical Analysis I		3
CSCE 462	Communication Networks		3
CSCE 488/401	(or ECEN 494) Senior Design I	401	3
CSCE 489/402	(or ECEN 495) Senior Design II	402	<u>3</u>
			42
Electrical Engineering Courses:			
ECEN 215, 235	Electronics & Circuits I, Lab		4
ECEN 216, 236	Electronics & Circuits II, Lab		4
ECEN 304	Cont Time Signals & Systems		3
ECEN 305	Probability Theory	270,370	3
ECEN 316	Electronics & Circuits III		<u>3</u>
			17
Mathematics Courses:			
MATH 106, 107, 208	Calc I,II,III		13
MATH 221	Differential Equations		3
MATH 314	Linear Alg (Matrix Theory)		<u>3</u>
			19
Additional Supporting Courses:			
Natural Sciences:			12-13
PHYS 211, 212 and one of CHEM 109 or PHYS 213 & lab	General Physics I,II (8 hr) General Chemistry (4 hr) or General Physics III & any lab (5 hr)		
Technical Communications:			6-9
JGEN 200 and one of JGEN 300 or COMM 286 or ENGR 100	Tech Comm I (subst ENGL 150+151) Tech Comm II (3 hr) or Bus & Prof Comm (3 hr) or Interpersonal Skills for Engr (3 hr)	287/8 187/8	
Technical Electives:	CSCE/ECEN/RAIK	370,371,403,404	15
ACE Courses:	LO's 5, 6, 7, 9	(LO 6): 182,282	12
Open Elective:	(to reach 126 hours)		<u>0-3</u>
			48

Professional Admission to Computer Engineering

- Officially at 43-61 hours, typically end of Soph year
- 2.500+ previous semester and cumulative GPA
- C+ min in MATH thru 208, PHYS thru 212, and ECEN 215/235
- C+ min in CSCE through 156 (RAIK 184), 230, 235 (RAIK 283)
- Automatic for qualifying students, will be contacted if at risk

Technical Electives Requirements - 15 hours

Technical Electives include the following:

- any Focus course
- any 300+ level non-required CSCE excepting 390 and 490
- any 300+ level non-required ECEN
- any 300+ level RAIK (if equivalent to qualifying CSCE)

Technical Electives constraints:

- I. ≥ 9 hours of CSCE and/or equivalent RAIK
 - II. ≥ 6 hours lecture-based
 - III. ≤ 6 hours practicum/internship (e.g. CSCE 403H, 404H, 491)
 - IV. ≤ 3 hours independent study (e.g. CSCE 498)
 - V. ≥ 9 hours 400-level
- 9+ hours in one Focus area with minimum C grade qualifies as a **Focus**.
 - 15+ hours in one Focus area with minimum C grade qualifies for waiver of preceding Technical Electives constraints.

ACE Student Learning Outcomes - 12 hours

- Maximum of 9 hrs in any one department for ACE 4-10.
- Asterisk (*) and **bold** indicates those not built into the major.
- See <http://ace.unl.edu/> for details and listings.

1.	Written Communication	JGEN 200, ENGL 150+151, Raikes
2.	Oral Communication	ENGR 100, COMM 286, JGEN 300, Raikes
3.	Math & Computation	CSCE 155E, Raikes
4.	Natural Sciences	CHEM 109, PHYS 211/212
5.*	Humanities/History	on your own!
6.*	Social Sciences	on your own! or Raikes
7.*	Fine Arts	on your own!
8.	Ethics	CSCE 488, RAIK 401
9.*	Human Diversity	on your own!
10.	Integrated Knowledge	CSCE 489, RAIK/CSCE 402, ECEN 495

Careful: ECEN 494 does NOT substitute for CSCE 488 to meet ACE 8 requirement!

Computer Engineering Focus Areas - 9-15 hours

Embedded Systems and Robotics

		Course Title	Frequency
CSCE	430	Computer Architecture	s
	<u>436</u>	<u>Embedded Systems</u>	fo
	438	Sensor Networks	se
	439	Robotics: Algos & Appls OR	fo!17
	476	Intro AI	fo
ECEN	479	Data Sys Org and Design	??
MECH	453	Robotics: Kinematics & Design	fs

VLSI Design

		Course Title	Frequency
ECEN	416	Mat & Dev for Comp Mem/Log/Disp	
	421	Princ of Semiconductor Mat & Def	f
	475	Digital Systems	s
CSCE	430	Computer Architecture	s
	<u>434</u>	<u>VLSI Design</u> OR	??
<u>ECEN</u>	<u>470</u>	<u>Digital & Analog VLSI Design</u> (Phys 213/223 also required)	s fs

Signal Processing & Communications

		Course Title	Frequency
ECEN	462	Communication Systems	f
	463	Digital Signal Processing	f
	464	Digital Comm Systems	so
	465	Intro to Data Compression	s
CSCE	438	Sensor Networks	se
	463	Data and Net Security (not s16)	se!18
	472	Digital Image Processing (not f15)	f
	473	Computer Vision	so

High Performance Computing

		Course Title	Frequency
<u>CSCE</u>	<u>430</u>	<u>Computer Architecture</u>	s
	432	High-Performance Processor Architectures	??
	435	Cluster & Grid Computing	fo
	437	File & Storage Systems	??
	455	Distributed Operatings Systems	so
	456	Parallel Algorithms & Programming	fe

- The Focus is optional and can be customized.
- Grade of C or higher is required for a Focus.
- Underlining means course is required for the Focus.

Computer Science Technical Electives

		Course Title	Frequency
CSCE	322	Programming Language Concepts	fssu
	378	Human-Computer Interaction	s
	399H	Honors Research (Ind Study)	fssu
	413	Database Systems	f
	421	Foundations of Constraint Sat Th	se
	423	Design & Analysis of Algorithms	s+fo
	425	Compiler Construction	s,!18
	428	Automata, Computation and Formal Lang	f+so
	430	Computer Architecture	s
	434	VLSI Design	??
	435	Cluster & Grid Computing	fo
	436	Advanced Embedded Systems	fo
	438	Sensor Networks	se
	439	Robotics	fo,!17
	441	Approximation of Functions	??
	447	Numerical Analysis II	??
	451	Operating System Principles	s+fo
	455	Distributed Operating Systems	so
	456	Parallel Algo's and Programming	fe
	457	Systems Administration	fo
	461	SOFT Adv Topics in Soft Engr	??
	463	Data & Network Security	se!18
	464	Internet Systems & Prog	s
	465	Wireless Comm Nets	fe
	466	SOFT Software Design and Arch	f18+3n
	467	SOFT Testing, Verif and Anal	f17+3n
	468	SOFT Req Elic, Modl and Anal	s18+3n
	470	Computer Graphics	fe
	471	Bioinformatics	??
	472	Digital Image Processing	f
	473	Computer Vision	so
	474	Data Mining	se
	475	Multiagent Systems	fo
	476	Artificial Intelligence	fo
	477	Cryptography & Comp Security	f
	478	Machine Learning	fe
	479	Neural Networks	??
	491	Internship (practicum)	fssu
	493	ILab Project (practicum)	fssu
	496	Special Topics (varies)	fs
	498	Computer Problems (Ind Study)	fssu

Electrical Engineering Technical Electives

EE Opt	Course Title	Frequency
	306 Electromag Field Theory	fs
	307 Elect Engr Lab I	fs
	317 Elect Engr Lab 2	fs
ECE	361 Adv Electronics & Circ	s
	399H Undergraduate Research (Ind Study)	fs
eps	406 Power Systems Analysis	fe
EFO	408 Engineering Electromagnetics	f
csp	410 Multivariate Random Processes	fo
md	417 Semiconductor Fundamentals II	s
md	420 Plasma Semiconductors	f
MD	421 Principles of Semiconductors	f
md	422 Intro to Phys & Chem of Solids	?
EPS	428 Power Electronics	f
eps	430 Wind Energy	f
eps	436 Electric Machines	s
EPS	438 Electric Power Engineering	s
	442 Analytical Techniques	so
eps	444 Linear Control Systems	f
ms	448 Decision Analysis	f
BIO	452 Bioinformatics	f
bio	460 LabView Programming	s
CSP	462 Communication Systems	f
CSP	463 Digital Signal Processing	f
csp	464 Digital Communication Systems	so
csp	465 Intro Data Compression	se
efo	467 Electromag Theory & Appl	?
efo	468 Microwave Engineering	?
ece	469 Analogue Integrated Circuits	f
ece	470 Digital & Analogue VLSI Design	s
ECE	475 Digital Systems	s
efo	480 Lasers & Laser Applications	s
efo	486 Applied Photonics	fo
	498 Special Topics	fs

Electrical Engineering Dual Matriculation?

Include the Following Courses:	hrs
Two of CHEM 109, PHYS 213, LIFE 120/121	4
PHYS 222, ECEN 306, 307, 317, 222 or CSCE 236	8
Choice ECEN 494&495, CSCE 488&489 or 401&402	0
EE Option 12 hrs from above list	6

(Need one from UPPER case, one from EiThEr case,
one from a different Option, and one of any upper EE)

Electrical Engineering Major Options

CSP/csp	- Communications & Signal Processing
EFO/efo	- Electromagnetic Fields & Optics
ECE/ece	- Electronics & Computer Engineering
EPS/eps	- Energy & Power Systems
MD/md	- Materials & Devices
BIO/bio	- Bioengineering

Recent CSCE 496 Special Topics Electives

Title	Frequency
Algorithms - Large Scale Data	so
AI and Heuristics in Software Engr	fo
Computational Methods in Bioinfo	fe
Data Visualization	fe
Exploring Virtual Reality	s
Genetically Engineered Sys	fe
Human-Robot Interaction	f
Molecular & Nanoscale Communication	se
Multiway Data Analysis	??
Perf Optimztn Comp System&Netwk	fo
Real-Time Systems	s
Queuing Models	fo!17
Self-Managing Comp Sys	fe
Software Engineering Robotics	??

Computer Science Dual Matriculation?

Add the Following Courses (need 150 hours):	hrs
CSCE 322 as a Technical Elective	0
CSCE 423 or 428 as a Technical Elective	0
CDR A (a second ACE 1) or ENGL 150 & 151	3
CDR C (Hum/Hist)	3
CDR D (Soc Sci)	3
	9

Engineering Mathematics Minor?

The minor includes MATH 106, 107, 208, 221 plus 12 advanced hours. Computer Engineering already includes MATH 314 and MATH 440 (cross-listed as CSCE 440). Simply add two more math courses.

Recent Changes

Fall 2009 through Fall 2010: ACE General Studies formula replaced the old ES/IS. Technical Electives were 9 hours. Required courses CSCE 430, ECEN 307, 361, and 475 become electives in Fall 2011. CSCE 236 not yet created.

Fall 2011: Required courses reduced, CSCE 236 added, Technical Elective hours increased to 15. Technical Electives not restricted by type (ECEN, Raikes, etc.) but ECEN limited to only 8 courses that were most relevant, also a few theory oriented CSCE courses were not allowed.

Fall 2012 through present: Technical Elective hours now constrained by type, but choices expand to virtually any upper-level ECEN and CSCE courses.

Bulletin year defaults to year matriculated into the program. Updating to a more recent year (of matriculation) can be done. Make request through Chief Undergraduate Adviser to the Dean's Office.

Example Eight Semester Schedule - 126 hours

Fall 1				Spring 1			
CSCE	155E	CS I	3	CSCE	156	CS II	4
MATH	106	Calc I	5	CSCE	235	Discrete	3
PHYS	211	Gen Phys I	4	CSCE	251	Unix	1
		ACE 5	3	MATH	107	Calc II	4
CSCE	10	Seminar	0	PHYS	212	Gen Phys II	4
			<u>15</u>				<u>16</u>
Fall 2				Spring 2			
CSCE	230	Comp Org	4	CSCE	236	Intr Em Sys	3
CSCE	310	Algos	3	CSCE	361	Soft Engr	3
MATH	208	Calc III	4	MATH	221	Diff Eq	3
ECEN	215,235	Elec Circ I	4	ECEN	216,236	Circuit II	4
ENGR	020	Seminar	0	JGEN	200	Tech Comm I	3
			<u>15</u>				<u>16</u>
Fall 3				Spring 3			
CSCE	351	Op Sys Ker	3	CSCE	335	Dig Logic	3
CHEM	109	Gen Chem	4	CSCE	462	Comm Net	3
ECEN	304	Sig & Sys	3	MATH	314	Linear Alg	3
ECEN	316	Circuit III	3	ECEN	305	Prob Th	3
		ACE 6	3	CS/EE		Tech Elec	3
			<u>16</u>				<u>15</u>
Fall 4				Spring 4			
CSCE	440	Num Anal	3	CSCE	489	CE Sr Des	3
CS/EE		Tech Elec	3	CS/EE		Tech Elec	3
CSCE	488	CE Prof	3	CS/EE		Tech Elec	3
JGEN	300	Tech Comm II	3	CS/EE		Tech Elec	3
		ACE 7	3			ACE 9	3
		free elective	3				<u>15</u>
			<u>18</u>				

Departmental Advising:

<http://cse.unl.edu/undergraduate-advising-center>

Charles Riedesel (Department Advisor) 259 Avery, 472-3486, chuckr@unl.edu

(calendar at <http://cse.unl.edu/~riedesel> follow link to appointments)

Kasey Juel (Advisor) W204 Nebraska Hall, 472-3160, kjuel@unl.edu

General College Advising:

Engineering Library, W204 Nebraska Hall, 472-7072

<http://engineering.unl.edu/current-undergraduate/index.shtml>

Math Placement see <http://www.math.unl.edu/resources/undergraduate/mpe/>

MINOR IN COMPUTER SCIENCE
 CSCE155, 156, plus 11 hrs of
 electives (at least one at 3/400 level)

Math minor add:
 two more math courses

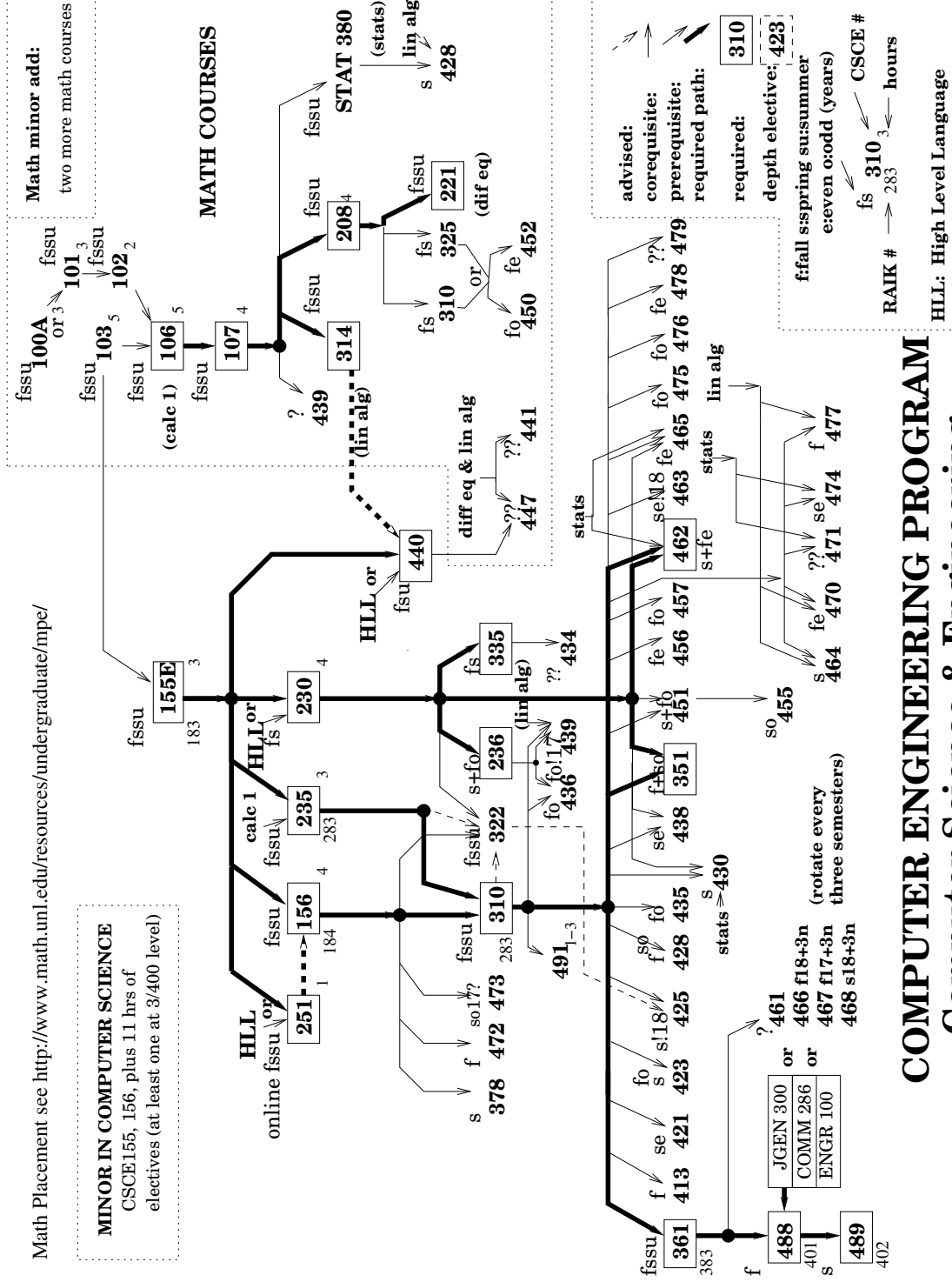

COMPUTER ENGINEERING PROGRAM

Computer Science & Engineering and Supporting Courses

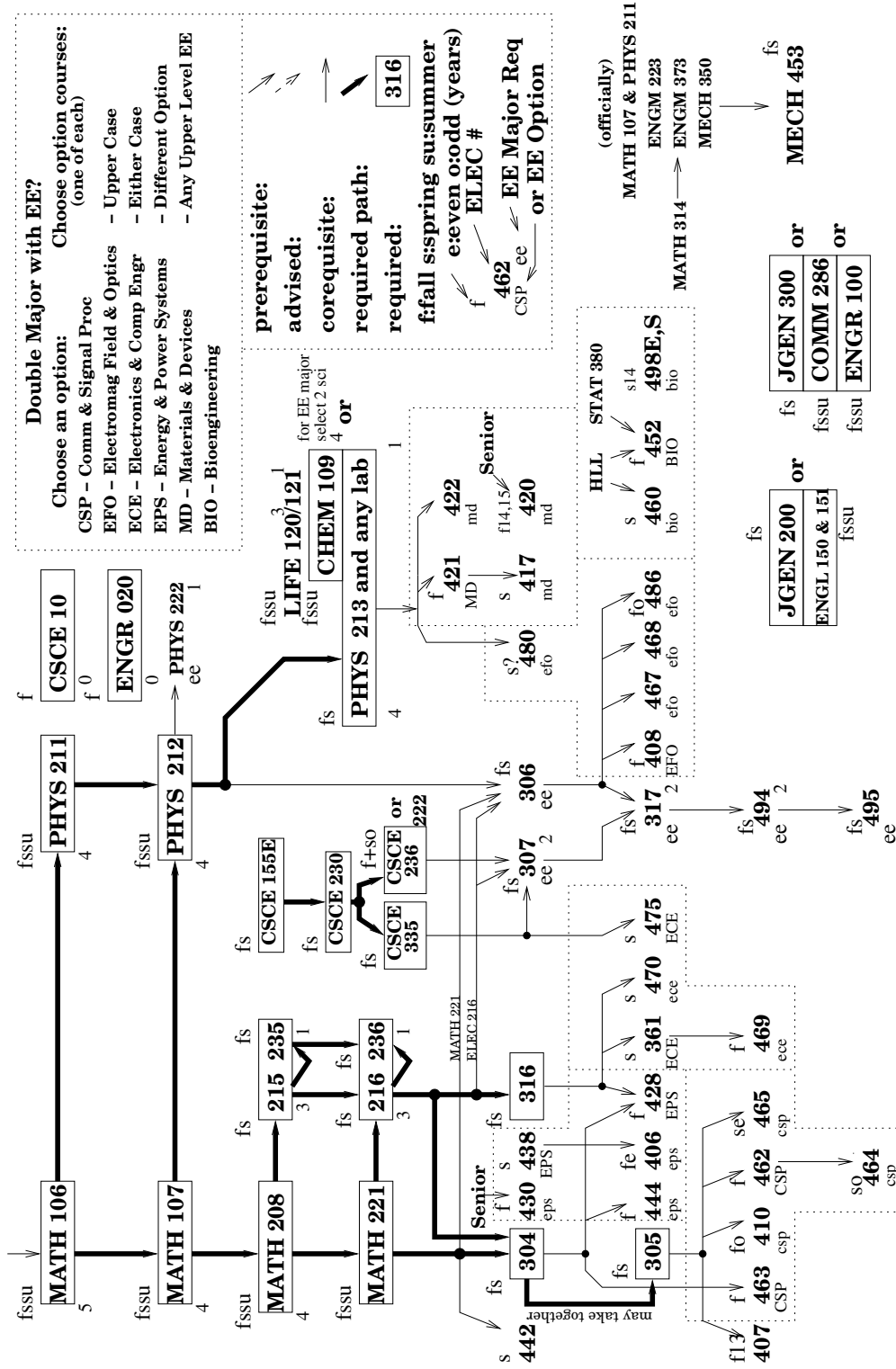

COMPUTER ENGINEERING PROGRAM

Electrical Engineering and Supporting Courses

rev 06/07/2017