

UNIVERSITY OF
Nebraska
Lincoln

Pioneering new frontiers.

Bachelor of Science in
Computer Engineering

Advising Brochure
2010 – 2011

Department of
Computer Science & Engineering
College of Engineering

256 Avery Hall

info@cse.unl.edu
<http://cse.unl.edu>

rev: June 4, 2010

Computer Engineering Program – 126 hours

Computer Science & Engineering Courses:

Course	Title	RAIK	Hrs
CSCE 155,156	Intro to Comp Sci I,II	183,184	8
CSCE 230,230L	Computer Organization, Lab	284	4
CSCE 235	Introduction to Discrete Struct	(283)	3
CSCE 251	Unix Programming		1
CSCE 310	Data Structures & Algos	283	3
CSCE 340	Numerical Analysis I		3
CSCE 351	Operating System Kernels		3
CSCE 361	Intro to Software Engineering	383	3
CSCE 430	Computer Architecture		3
CSCE 462	Communication Networks		3
CSCE 488	CE Professional Development		2
CSCE 489	CE Senior Design Project		<u>3</u>
			39

Electrical Engineering Courses:

ELEC 215,235	Electronics & Circuits I, Lab		4
ELEC 216,236	Electronics & Circuits II, Lab		4
ELEC 304	Cont Time Signals & Systems		3
ELEC 305	Probability Theory		3
ELEC 316	Electronics & Circuits III		3
ELEC 361,307	Adv. Electronics & Circ, Lab		5
ELEC 370	Digital Logic Design		3
ELEC 475	Digital Systems		<u>3</u>
			28

Mathematics Courses:

MATH 106,107,208	Analytic Geom & Calc I,II,III		14
MATH 221	Differential Equations		3
MATH 314	Linear Alg (Matrix Theory)		<u>3</u>
			20

Other Supporting Courses:

PHYS 211,212	General Physics I,II		8
CHEM 109	General Chemistry		4
JGEN 200,300	Technical Writing I,II	287/8,187/8	6
ENGR 010,020	Frosh, Soph Engr Seminars		0
CSCE/ELEC	Technical Electives (6+ in CSCE)	301/2,401/2	9
ACE	Humanities & Social Sciences	182,282	<u>12</u>
			39

EE Double Major: ELEC 222,317,494, ALEC 102, PHYS 222,213,
choice of ELEC 495 or CSCE 489, choose EE option (see next page)

Computer Engineering Technical Electives
See last page for 496 Special Topics Selections

		Course Title	Frequency
CSCE	322 †	Programming Language Concepts	f
	378	Human Computer Interaction	se
	399H	Honors Thesis (max 3 hours)	fssu
	410	Information Retrieval Systems	
	413	Database Systems	fe
	421	Foundations of Constraint Sat Theory	so
	425	Compiler Construction	fo
	432	High-Performance Processor Architectures	fo
	434	VLSI Design	fe
	435	Cluster & Grid Computing	fo
	437	File & Storage Systems	so
	451	Operating System Principles	se
	455	Distributed Operatings Systems	fe
	456	Parallel Algorithms & Programming	fe
	457	Systems Administration	fe
	464	Internet Systems & Programming	se
	470	Computer Graphics	
	471	Bioinformatics	se
	472	Digital Image Processing	f
	473	Computer Vision	so
	474	Data Mining	fe
	475	Multiagent Systems	fo
	476	Artificial Intelligence	so
	477	Cryptography & Computer Security	
	478	Machine Learning	fe
	479	Neural Networks	
	491	Internship (case by case, max 3 hours)	fssu
RAIK		301,302,401,402 Design Studio	
ELEC	306 ‡	Electromagnetic Field Theory	fs
	417	Integrated Circuits	fs
	462 C	Communication Systems	f
	463 C	Digital Signal Processing	s
	464 C	Digital Communication Systems	s
	465 C	Intro to Data Compression	s
	469 E	Analog Integrated Circuits	f
	470 E	Digital & Analog VLSI Design	s

†Deficiency for the graduate program!

‡Needed for Elec Engr (double) major! Plus an option:

Communications & Signal Proc - pick 2 from *C*, at least 1 bold.

Electronics & Comp Engr - pick any 2 ELEC, at least 1 not *E*.

Recent CSCE 496 Special Topics Electives

Data and Network Security (se)
Embedded Systems (s)
Self-Managing Computer Systems (fo)
Sensor Networks (fe)
Software Architecture
Steganography

ACE Student Learning Outcomes Requirements:

Maximum of 9 hrs in any one department for ACE 4-10.
Asterisk (*) indicates those not built in the major.

- | | | |
|-----|-----------------------|---|
| 1. | Written Communication | JGEN 200, RAIK 287/288 (in major) |
| 2. | Oral Communication | JGEN 300, RAIK 187/188 (in major) |
| 3. | Math & Computation | CSCE 155, RAIK 183 (in major) |
| 4. | Natural Sciences | CHEM 109 (in major) |
| 5.* | Humanities/History | 3 hours elective |
| 6.* | Social Sciences | 3 hours elective or RAIK 182 |
| 7.* | Fine Arts | 3 hours elective |
| 8. | Ethics | Distrib in major or RAIK 282 |
| 9.* | Human Diversity | 3 hours elective |
| 10. | Integrated Knowledge | CSCE 489, RAIK 402, ELEC 495 (in major) |

Formal Admission to Computer Engineering

Required prior to taking upper level engineering courses!

- 43 – 61 hours applicable to the program is completed
- Cumulative and Semester GPA at least 2.500
- Grade of C+ or higher in
 - MATH through 208
 - PHYS through 212
 - ELEC through 215/235
 - CSCE through 156, 230, and 235 (or RAIK 183, 184, 283)

If and when you qualify for formal admission, you will be notified and will not need to do anything. Your advisor will take care of the paperwork. You will also be notified if you are in danger of not qualifying.

Example Eight Semester Schedule - 126 hrs

Fall 1					Spring 1			
CSCE	155	CS I	4		CSCE	156	CS II	4
MATH	106	Calc I	5		CSCE	235	Discrete	3
CHEM	109	Gen Chem I	4		CSCE	251	Unix	1
ENGR	010	Seminar	0		MATH	107	Calc II	5
		ACE 5	3		PHYS	211	Gen Phys I	4
			<u>16</u>					<u>17</u>
Fall 2					Spring 2			
CSCE	230	Comp Org	3		CSCE	310	Algos	3
CSCE	230L	Lab	1		MATH	221	Diff Eq	3
MATH	208	Calc III	4		ELEC	370	Dig Logic	3
PHYS	212	Gen Phys II	4		ELEC	216,236	Circuit II	4
ELEC	215,235	Elec Circ I	4		JGEN	200	Tech Comm I	3
ENGR	020	Seminar	0					<u>16</u>
			<u>16</u>					
Fall 3					Spring 3			
CSCE	351	Op Sys Ker	3		CSCE	462	Comm Net	3
CSCE	361	Soft Engr	3		MATH	314	Linear Alg	3
ELEC	304	Sig & Sys	3		ELEC	305	Prob Th	3
ELEC	316	Circuit III	3		ELEC	307	Elec Lab I	2
		ACE 6	3		ELEC	361	Adv Elec	3
			<u>15</u>		ELEC	475	Dig Sys	3
								<u>17</u>
Fall 4					Spring 4			
CSCE	340	Num Anal	3		CSCE	489	CE Sr Des	3
CSCE	430	Comp Arch	3		CS/EE		Tech Elec	3
CSCE	488	CE Prof	2		CS/EE		Tech Elec	3
JGEN	300	Tech Comm II	3		CS/EE		Tech Elec	3
		ACE 7	3				ACE 9	3
			<u>14</u>					<u>15</u>

For assistance with general college requirements, contact the
Engineering College Dean's Office, 114 Othmer Hall, 472-3181,
<http://engineering.unl.edu/specialty-units/eHelp/>

computer science placement exam at http://cse.unl.edu/placement_test/
 needed for csce 150(A,E,M), 155, or 156

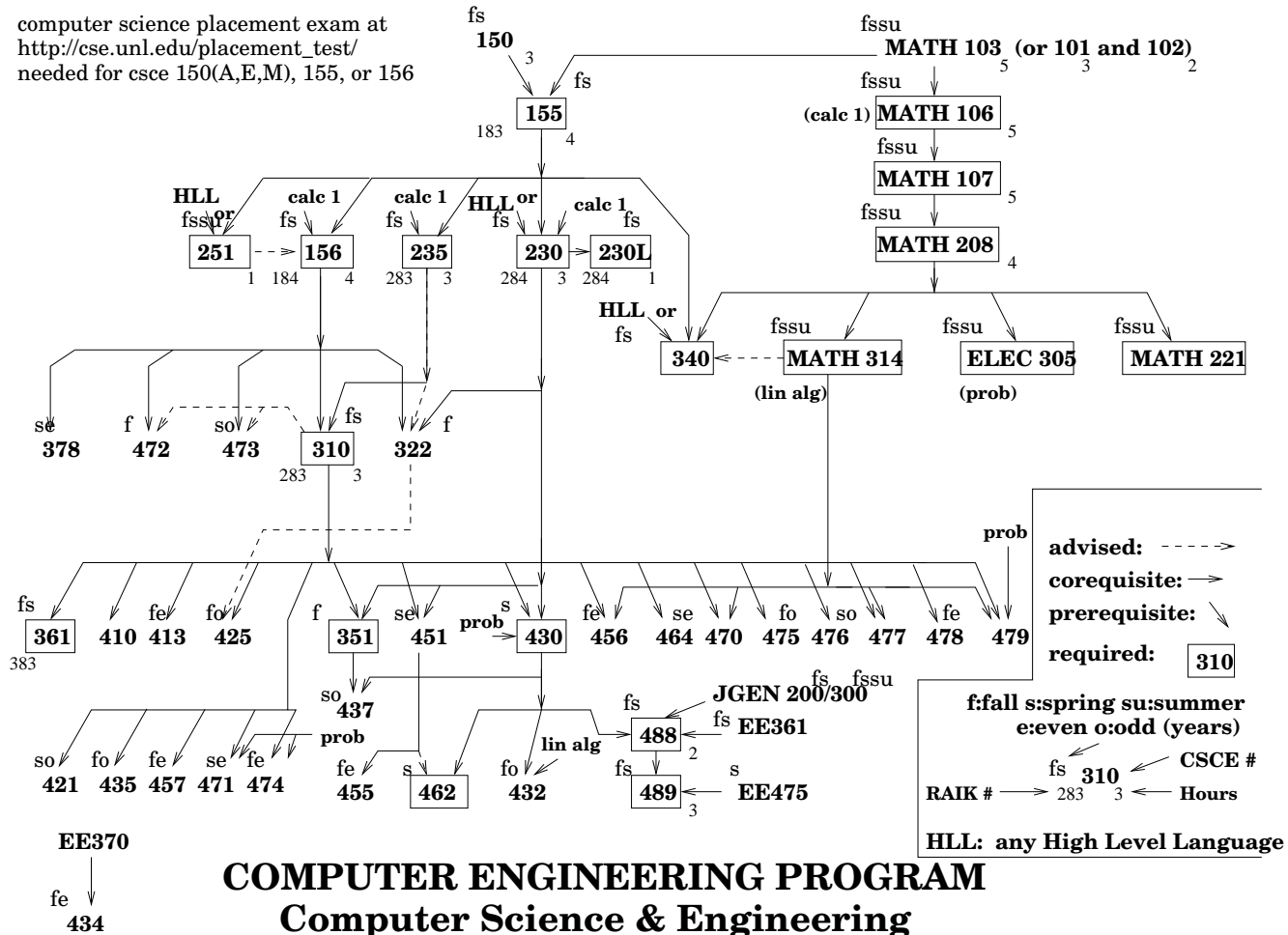

COMPUTER ENGINEERING PROGRAM
Computer Science & Engineering
and Supporting Courses

rev 06/4/10

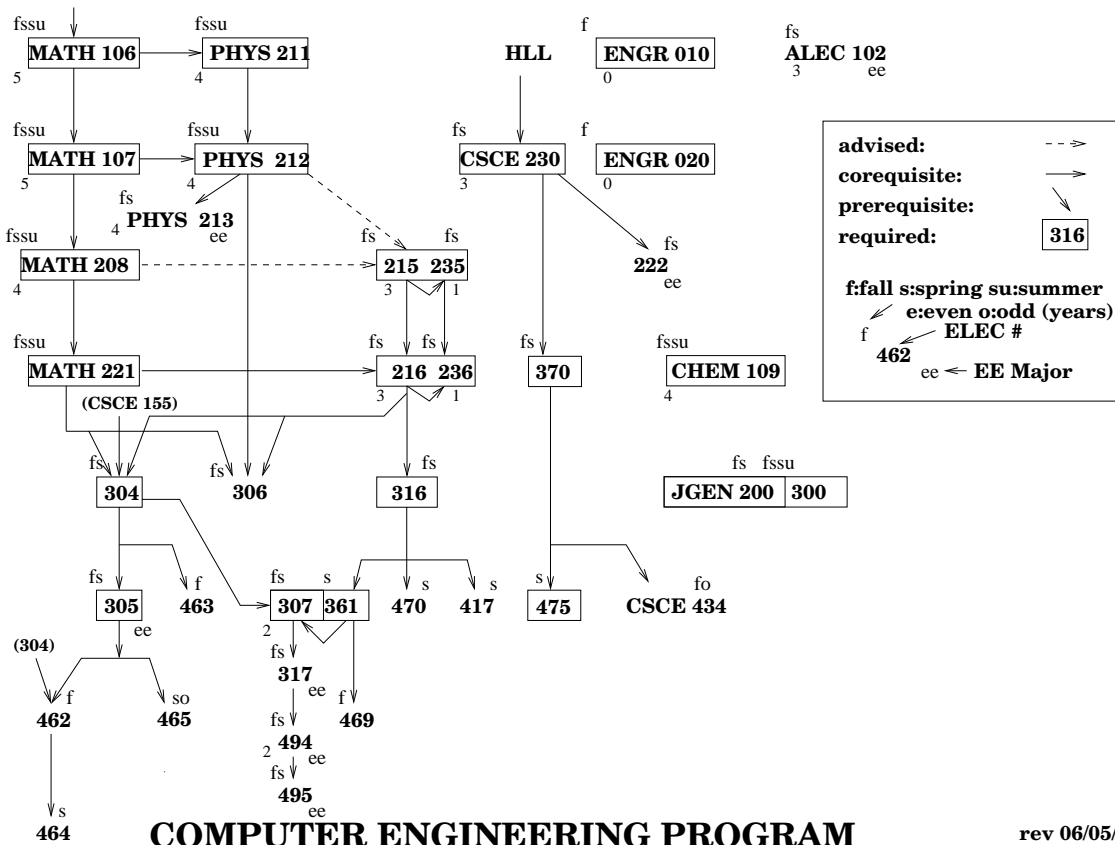

COMPUTER ENGINEERING PROGRAM
Electrical Engineering and Supporting Courses